

Selection of airports in Germany

**D**

# FRA-FRANKFURT AIRPORT (D)

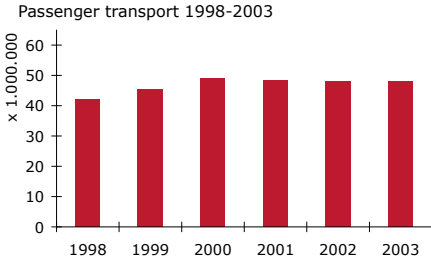

## CONNECTIVITY (summer 2004)

Destinations: 300  
 -Scheduled flights 300  
 -Holiday flights  
 Airlines 154

AIR TRAFFIC (statistics 2003, x 1.000)*	Air transport movements	Passenger transport (terminal)	Freight transport (metric tons)	Mail transport (metric tons)
*(Source: IATA, 2004)	458,9	48.107,7	1.527,2	123,4

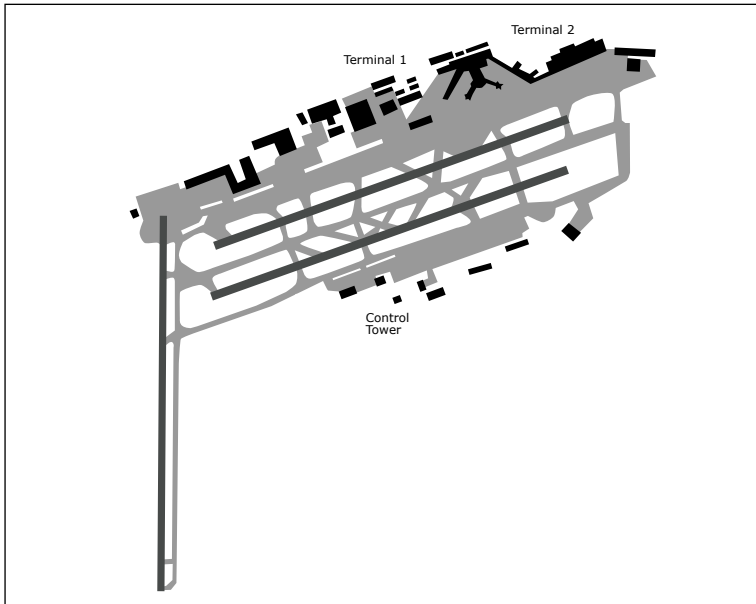

## AIRPORT-ORGANIZATION

Name / Address	Frankfurt/Main International, D-60547 Frankfurt/Main, Germany				
Website	www.frankfurt-airport.de				
IATA / ICAO code	FRA / EDDF				
Position (LAT/LONG)	50°02'04"N / 008°34'17"E				
Opening hours	05:00-23:00 hrs				
(Noise) restrictions	night curfew 23:00-05:00 hrs				
Operator	Fraport AG Frankfurt Airport Services Worldwide				
Employment (2002)*:	*(Source: ATAG, 2003)				
-Employed direct:	15.526		-Total on site (est.):	62.000	
Potential market area	1hr by car	2hrs by car	1hr by train	2hrs by train	weighted with distance decay
(2004, x 1 million pax):	7,6	24,7	6,0	25,5	9,3

## AIRPORT-INFRASTRUCTURE

Size	1.900 ha				
Runways:	3 -Longest length: 4.000 m				
-Runway 1	Heading 07L/25R, 4.000m, Aircraft size max: B747				
-Runway 2	Heading 07R/25L, 4.000m, Aircraft size max: B747				
-Runway 3	Heading 18/36, 4.000m, Aircraft size max: B747				
Apron (aircraft stands)	187				
Cargo terminal:	2	-Capacity cargo (tons):			4.500.000
Passenger terminal:	9	-Capacity passengers (annual):			60.000.000

## ACCESSIBILITY

-Train link:	Yes		-Nearest city: Frankfurt (12km)		
Modal split (2002)*:	Rail	Bus	Taxi	Private car	Others
*(Source: ATAG, 2003)	27%	6%	19%	47%	-
Parking area (spaces):	36.500				
-Parking fees (euros, 2004):	1 hr	1 day	7 days		
--short/long term	€ 3,00	€ 21,00	€105,00		

## PLANNED AIRPORT DEVELOPMENT

-Projects:	-Additional capacity:	-Year operation:	-Status:
Construction of 4th runway	Runway	2006	Planned
Construction of Terminal 3 + Apron area	Terminal, Apron	2007	Planned

-  Airport
-  Motorway
-  Railway
-  National border
-  Built area
-  Water

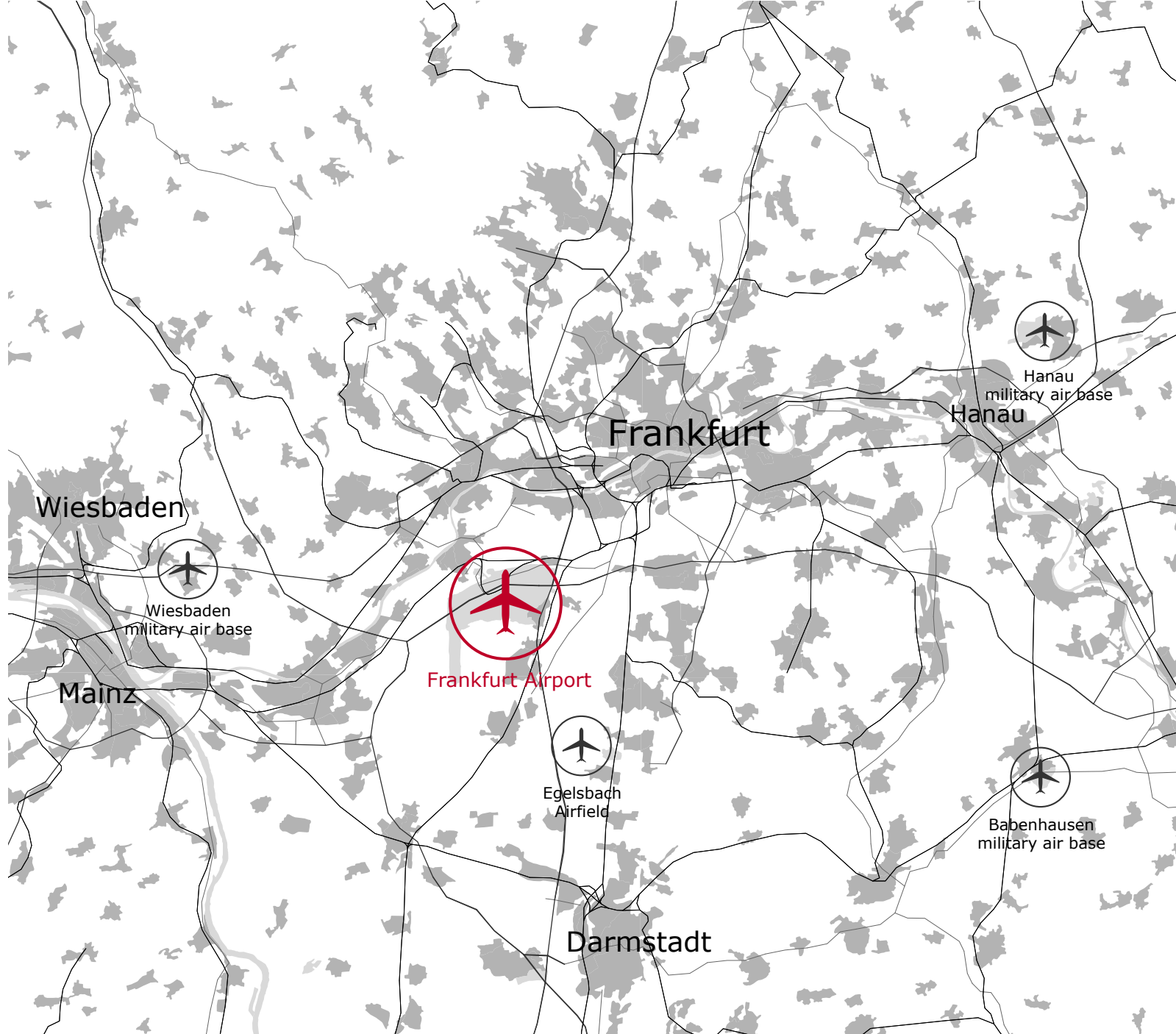

Frankfurt region

1:300.000

98 **DUS-DÜSSELDORF**  
**INTERNATIONAL AIRPORT**

**CONNECTIVITY** (summer 2004)

Destinations: 225

-Scheduled flights

-Holiday flights

Airlines 75

**AIR TRAFFIC**  
(statistics 2003, x 1.000)\*

\*(Source: IATA, 2004)

Air transport movements	Passenger transport (terminal)	Freight transport (metric tons)	Mail transport (metric tons)
186,2	14.172,9	47,4	0,1

Passenger transport 1998-2003

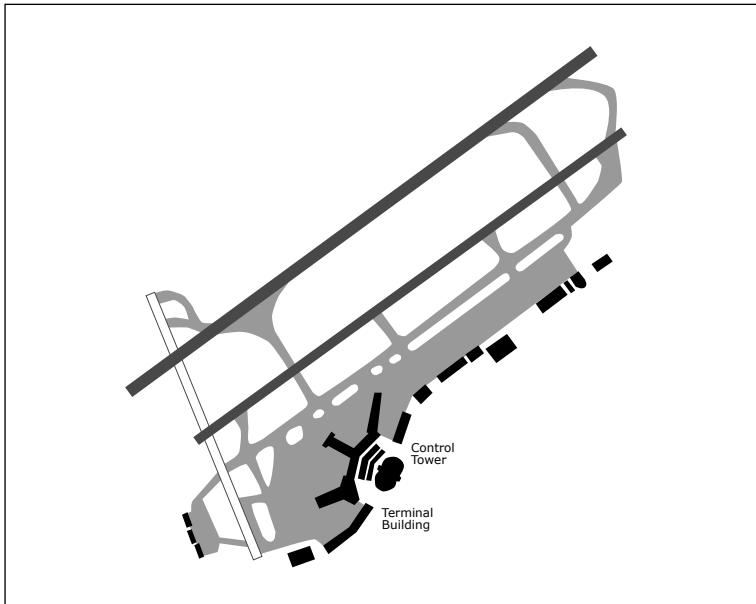
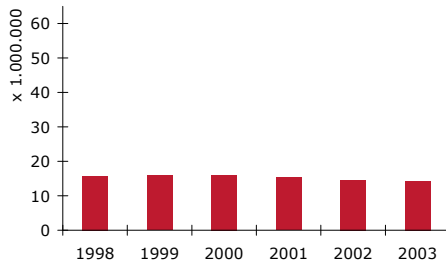

**AIRPORT-ORGANIZATION**

Name / Address	Düsseldorf International Airport, D-40403 Düsseldorf, Germany				
Website	www.duesseldorf-international.de				
IATA / ICAO code	DUS / EDDL				
Position (LAT/LONG)	51°16' 56"N / 006°45' 29"E				
Opening hours	24 hours				
(Noise) restrictions	night restrictions: 23:00-06:00 hrs, only Chapter 3 aircrafts allowed				
Operator	Flughafen Düsseldorf GmbH				
Employment (2002)*:	*(Source: ATAG, 2003)				
-Employed direct:	2.673				-Total on site (est.): 13.200
Potential market area	1hr by car	2hrs by car	1hr by train	2hrs by train	weighted with distance decay
(2004, x 1 million pax):	15,1	36,0	11,9	41,2	14,5

**AIRPORT-INFRASTRUCTURE**

Size	613 ha	
Runways:	3	-Longest length: 3.000m
-Runway 1	Heading 05R/23L, 3.000m, Aircraft size max: B747	
-Runway 2	Heading 05L/23R, 2.900m	
-Runway 3	Heading 15/33, 1.650m	
Apron (aircraft stands)	76	
Cargo terminal:	2	-Capacity cargo (tons): 130.000
Passenger terminal:	4	-Capacity passengers (annual): 15.000.000

**ACCESSIBILITY**

Modal split (2002)*:	Rail	Bus	Taxi	Private car	Others
*(Source: ATAG, 2003)	18%	4%	21%	51%	-
Parking area (spaces):	10.500	of 11.600?			
-Parking fees (euros, 2004):	1 hr	1 day	7 days		
--short term	€ 3,00	€ 24,00	€168,00		
--long term	€ 2,00	€ 16,00	€ 48,00		

**PLANNED AIRPORT DEVELOPMENT**

-Projects:	-Additional capacity:	-Year operation:	-Status:
Completion terminal (17 million pax)	Terminal	2003	Actual
Additional Pier	Terminal	?	Planned
New railway station	Others	?	Planned

-  Airport
-  Motorway
-  Railway
-  National border
-  Built area
-  Water

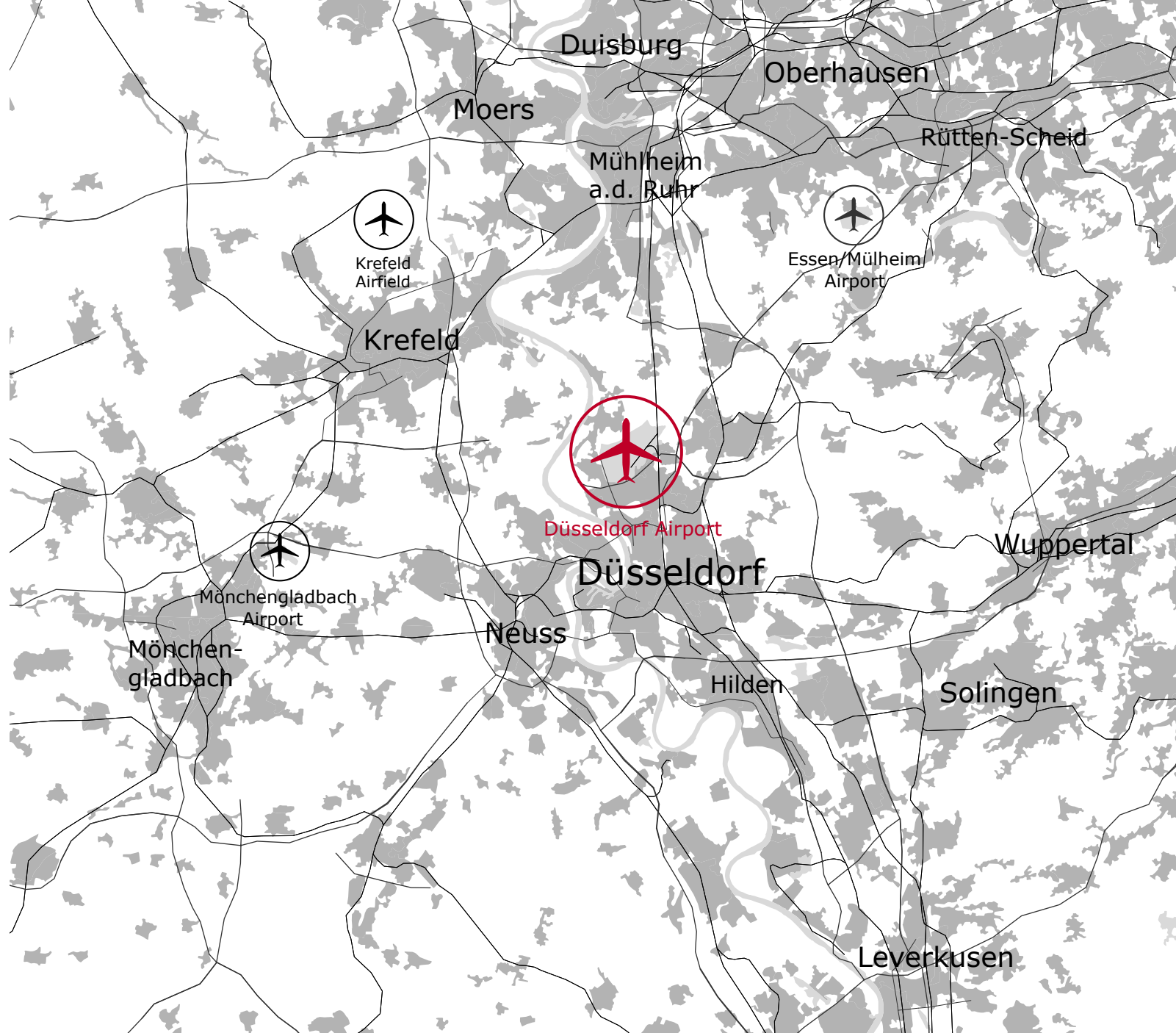

Düsseldorf region

1:300.000

# HAM - HAMBURG AIRPORT (D)

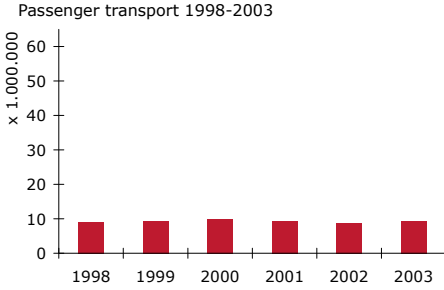

## CONNECTIVITY (summer 2004)

Destinations:	240
-Scheduled flights	240
-Holiday flights	60
Airlines	74

AIR TRAFFIC (statistics 2003, x 1.000)*	Air transport movements	Passenger transport (terminal)	Freight transport (metric tons)	Mail transport (metric tons)
*(Source: IATA, 2004)	149,4	9.424,8	23,2	12,8

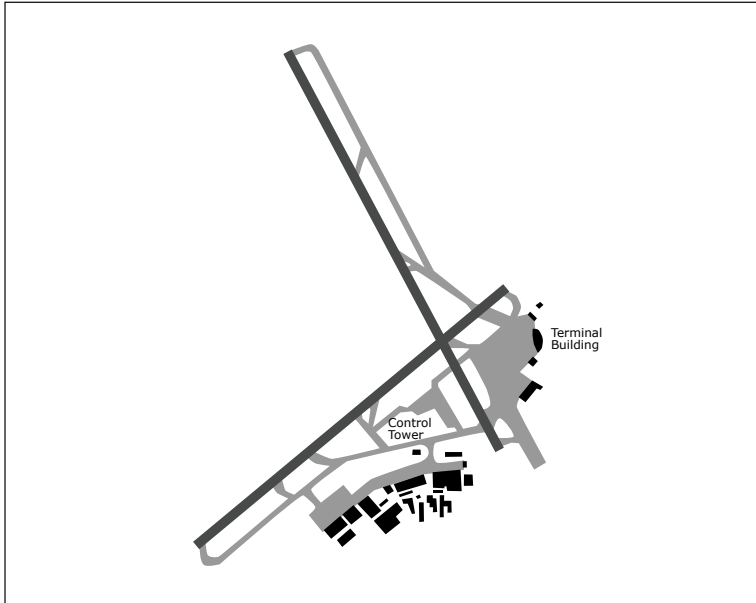

## AIRPORT-ORGANIZATION

Name / Address	Hamburg Airport, Flughafenstraße 1-3, D-22335 Hamburg, Germany				
Website	www.ham.airport.de				
IATA / ICAO code	HAM / EDDH				
Position (LAT/LONG)	53°37' 55"N / 009°59' 22"E				
Opening hours	07:00-22:00 hrs; Chapter 3 aircrafts allowed: 06:00-23:00 hrs				
(Noise) restrictions	-				
Operator	Flughafen Hamberg GmbH				
Employment (2003)*:	*(Source: website airport)				
-Employed direct:	1.661		-Total on site:	12.307	
Potential market area	1hr by car	2hrs by car	1hr by train	2hrs by train	weighted with distance decay
(2004, x 1 million pax):	4,5	10,1	3,4	8,5	6,0

## AIRPORT-INFRASTRUCTURE

Size	570 ha				
Runways:	2 -Longest length: 3.665m				
-Runway 1	Heading 05/23, 3.250m, Aircraft size max: No Restriction				
-Runway 2	Heading 15/33, 3.665m, Aircraft size max: No Restriction				
Apron (aircraft stands)	65				
Cargo terminal:	1		-Capacity cargo (tons):	110.000	
Passenger terminal:	3		-Capacity passengers (annual):	11.000.000	

## ACCESSIBILITY

	-Train link: No -Bus link:Shuttlebus -Nearest city:Hamburg(8km)				
Modal split:	Rail	Bus	Taxi	Private car	Others
	-	-	-	-	-
Parking area (spaces):	8.900				
-Parking fees (euros, 2004)	1 hr	1 day	7 days		
--short term	€ 2,00	€16,00	€112,00		
--long term (Holidaypark)	€ 2,00	€ 6,00	€ 27,00		

## PLANNED AIRPORT DEVELOPMENT

-Projects:		-Additional capacity:	-Year operation:	-Status:
Replacement terminal 2		Terminal	2005	Planned
Construction of S-Bahn suburban raillink	Others		2005	Planned

-  Airport
-  Motorway
-  Railway
-  National border
-  Built area
-  Water

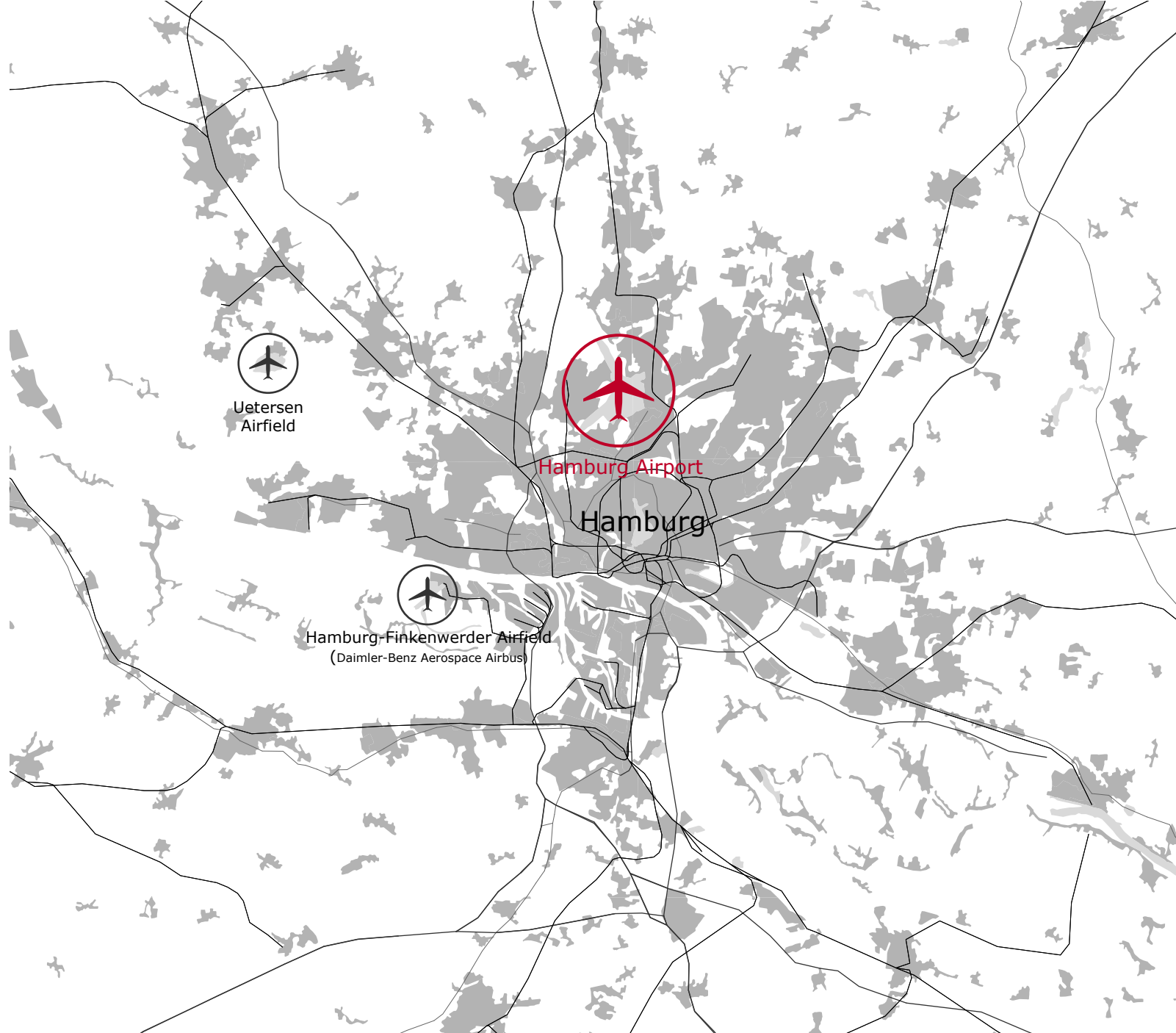

Hamburg region

1:300.000



# CGN - COLOGNE-BONN AIRPORT (D)

## CONNECTIVITY (summer 2004)

Destinations: 115  
 -Scheduled flights  
 -Holiday flights  
 Airlines 53

AIR TRAFFIC (statistics 2003, x 1.000)*	Air transport movements	Passenger transport (terminal)	Freight transport (metric tons)	Mail transport (metric tons)
*(Source: IATA, 2004)	153,4	7.697,7	518,5	12,6

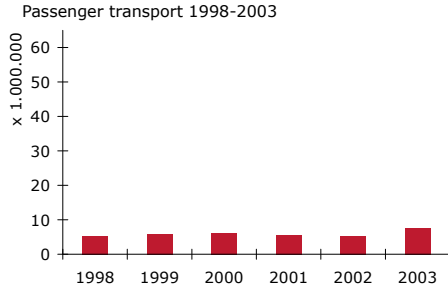

## AIRPORT-ORGANIZATION

Name / address: Cologne-Bonn Airport, Waldsrasse 247, D-51147 Cologne, Germany  
 Website: www.airport-cgn.de  
 IATA / ICAO code: CGN / EDDK  
 Position (LAT/LONG): 50°52'02"N / 007°08'37"E  
 Opening hours: 24 hours: only for Chapter 3 aircrafts, others on day time only  
 (Noise) restrictions: S´AIP-Germany  
 Operator: Flughafen Köln/Bonn GmbH  
 Employment (2002)\*: \*(Source: ATAG, 2003)  
 -Employed direct: 1.640 -Total on site (est.): 9.500  
 Potential market area: 1hr by car 2hrs by car 1hr by train 2hrs by train weighted with distance decay  
 (2004, x 1 million pax): 12,9 32,5 6,4 24,5 12,4

## AIRPORT-INFRASTRUCTURE

Size: 1.000 ha  
 Runways: 3 -Longest length:3.815m  
 -Runway 1: Heading 14L/32R, 3.800m, Aircraft size max: All types  
 -Runway 2: Heading 14R/32L, 1.866m  
 -Runway 3: Heading 07/25, 2.459m, Aircraft size max: All types  
 Apron (aircraft stands): 113  
 Cargo terminal: 9 -Capacity cargo (tons): -  
 Passenger terminal: 2 -Capacity passengers (annual): 12.000.000

## ACCESSIBILITY

-Train link: Yes -Nearest city: Cologne (15km)  
 Modal split (2002)\*: Rail Bus Taxi Private car Others  
 \*(Source: ATAG, 2003) 20% 5% 20% 55% -  
 Parking area (spaces): 12.000  
 -Parking fees (euros, 2004): 1 hr 1 day 7 days  
 --short term €2,00 €14,00 €40,00  
 --long term €1,00 € 8,00 €22,00

## PLANNED AIRPORT DEVELOPMENT

-Projects: -Additional capacity: -Year operation: -Status:  
 Enlargement Pax - terminal 1 Terminal 2004 Actual  
 Enlargements cargo-terminals Terminal 2005 Planned

-  Airport
-  Motorway
-  Railway
-  National border
-  Built area
-  Water

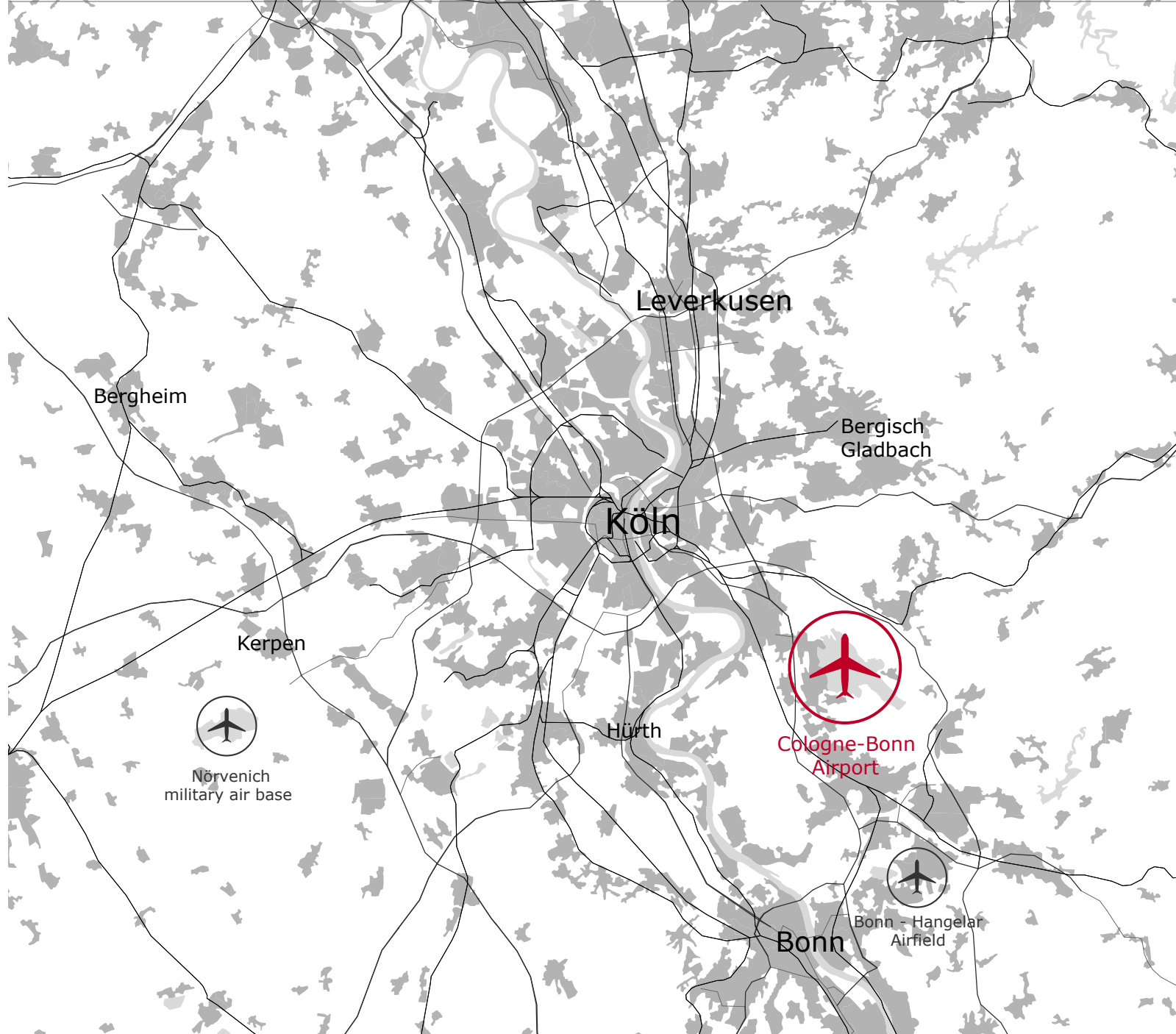

Cologne region

1:300.000

# STR-STUTTGART AIRPORT (D)

## CONNECTIVITY (summer 2004)

Destinations: 118

-Scheduled flights

-Holiday flights

Airlines 60

## AIR TRAFFIC (statistics 2003, x 1.000)\*

\*(Source: IATA, 2004)

Air transport movements	Passenger transport (terminal)	Freight transport (metric tons)	Mail transport (metric tons)
144,9	7.464,9	17,5	9,9

Passenger transport 1998-2003

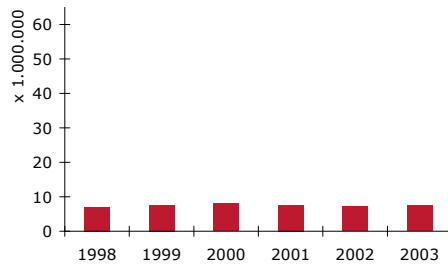

## AIRPORT-ORGANIZATION

Name / Address	Stuttgart Airport, D-70624 Stuttgart, Germany				
Website	www.stuttgart-airport.com				
IATA / ICAO code	STR / EDDS				
Position	48°41'27"N / 009°13'23"E				
Opening hours	06:00-23:00 hrs				
(Noise) restrictions	only chapter 3 permitted				
Operator	Flughafen Stuttgart				
Employment (2002)*:	*(Source: ATAG, 2003)				
-Employed direct:	1.251		-Total on site (est.):	7.500	
Potential market area	1hr by car	2hrs by car	1hr by train	1hrs by train	weighted with distance decay
(2004, x 1 million pax):	4,7	13,7	2,9	11,2	8,4

## AIRPORT-INFRASTRUCTURE

Size	400 ha				
Runways:	1 -Longest length: 3.345m				
-Runway 1	Heading 07/25, 3,345m, Aircraft size max: B747, AN124, C5				
Apron (aircraft stands)	40				
Cargo terminal:	2	-Capacity cargo (tons):			12.000
Passenger terminal:	4	-Capacity passengers (annual):			8.000.000

## ACCESSIBILITY

	-Train link: Yes	-Nearest city: Stuttgart (13km)			
Modal split (2002)*:	Rail	Bus	Taxi	Private car	Others
*(Source: ATAG, 2003)	21%	2%	10%	60%	7%
Parking area (spaces):	10.000				
-Parking fees (euros, 2004):	1 hr	1 day	7 days		
--short term	€ 3,00	€25,50	€178,50		
--long term	free	€18,00	€ 46,00		
--P hotel	€ 3,00	€26,00	€ 77,00		

## PLANNED AIRPORT DEVELOPMENT

-Projects:	-Additional capacity:	-Year operation:	-Status:
Terminal 3	Terminal	2004	Actual

-  Airport
-  Motorway
-  Railway
-  National border
-  Built area
-  Water

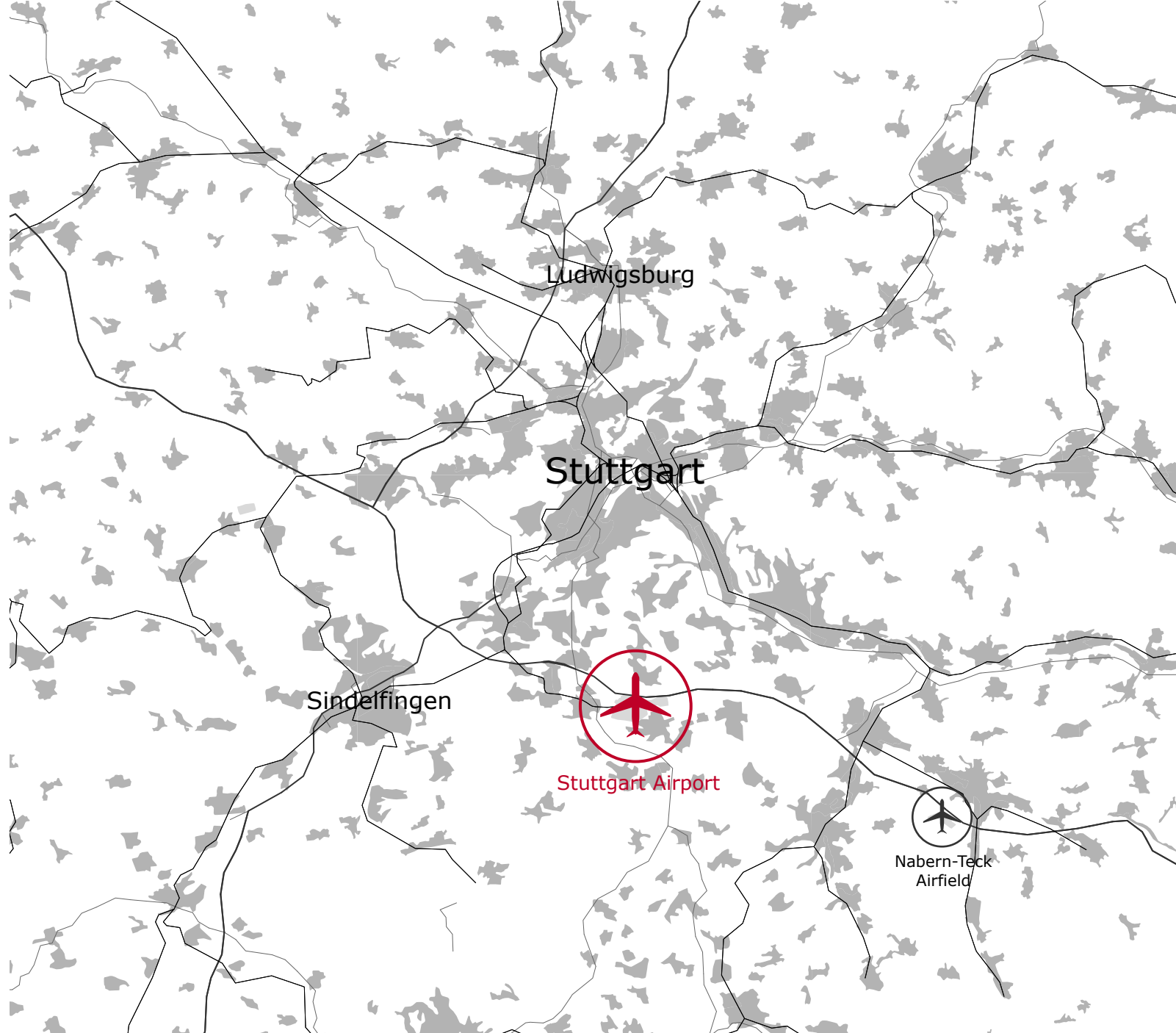

Stuttgart region

1:300.000

# HAJ - HANNOVER AIRPORT (D)

## CONNECTIVITY (summer 2004)

Destinations:	121
-Scheduled flights	38
-Holiday flights	83
Airlines	27

## AIR TRAFFIC (statistics 2003, x 1.000)\*

Air transport movements	Passenger transport (terminal)	Freight transport (metric tons)	Mail transport (metric tons)
86,4	4.962,1	5,3	9,9

\*(Source: ITA, 2004)

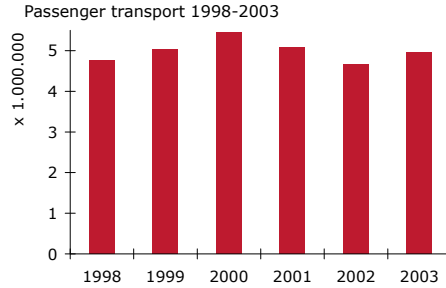

## AIRPORT-ORGANIZATION

Name / Address	Hannover Airport, D-30662 Hannover, Germany				
Website	www.flughafen.hannover.de				
IATA / ICAO code	HAJ / EDDV				
Position (LAT/LONG)	52°27' 42"N / 009°41' 05"E				
Opening hours	24 hours				
(Noise) restrictions	Chapter 2 aircrafts are not permitted between 22:00-06:00 No restrictions on night landings/take offs with Chapter 3 aircrafts				
Operator	Flughafen Hannover-Lagenhagen GmbH				
Employment:					
-Employed direct:	-				-Total on site (est.): -
Potential market area	1hr by car	2hrs by car	1hr by train	2hrs by train	weighted with distance decay
(2004, x 1 million pax):	3,8	16,6	3,2	15,2	6,3

## AIRPORT-INFRASTRUCTURE

Size	- (ha)				
Runways:	2 -Longest length:3.800m				
-Runway 1	Heading 09L/27R, 3,800m, Aircraft size max: All Types				
-Runway 2	Heading 09R/27L, 2,340m				
Apron (aircraft stands)	-				
Cargo terminal:	1	-Capacity cargo (tons):			100.000
Passenger terminal:	1	-Capacity passengers (annual):			4.500.000
<b>ACCESSIBILITY</b>	-Train link: No -Suburban railwayS5 -Nearest city:Hannover (11km)				
Modal split:	Rail	Bus	Taxi	Private car	Others
	-	-	-	-	-
Parking area (spaces):	7.151				
-Parking fees(euros, 2004)	1 hr	1 day	7 days		
--short term	€2,00				
--long term	€2,00	€12,00	€57,00		
--exclusive parking	€8,00	€18,00	€93,00		

## PLANNED AIRPORT DEVELOPMENT

-Projects:	-Additional capacity:	-Year operation:	-Status:
-			

-  Airport
-  Motorway
-  Railway
-  National border
-  Built area
-  Water

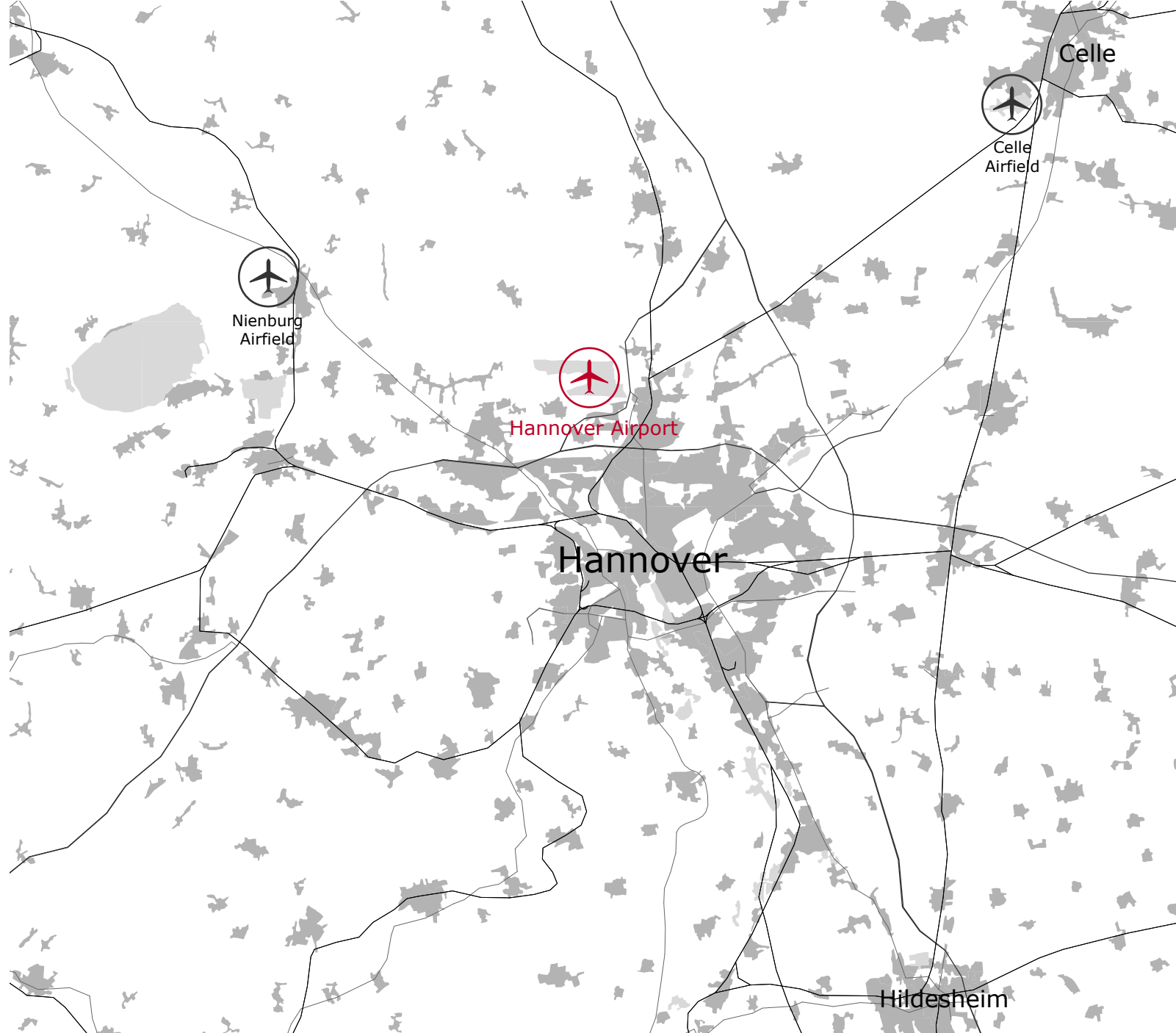

Hannover region

1:300.000

108 **HHN - FRANKFURT HAHN AIRPORT (D)**

**CONNECTIVITY** (summer 2004)

Destinations: 27  
 -Scheduled flights  
 -Holiday flights  
 Airlines 7

<b>AIR TRAFFIC</b> (statistics 2003, x 1.000)*	Air transport movements	Passenger transport (terminal)	Freight transport (metric tons)	Mail transport (metric tons)
*(Source: IATA, 2004)	31,1	2.417,1	36.575,9	0,5

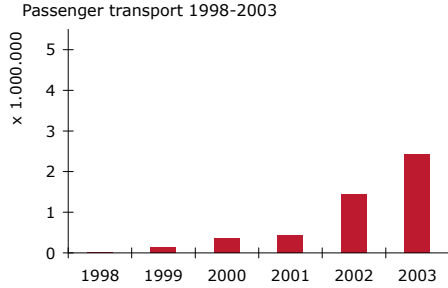

**AIRPORT-ORGANIZATION**

Name / Address Frankfurt-Hahn Airport, Gebäude 667, D-55483 Hahn Airport, Germany  
 Website www.hahn-airport.de  
 IATA / ICAO code HHN / EDFH  
 Position (LAT/LONG) 49°56'54"N / 007°15'51"E  
 Opening hours 24 hours  
 (Noise) restrictions night curfew for Chapter 2 aircraft 22:00-06:00 hrs  
 Operator Flughafen Frankfurt-Hahn GmbH  
 Employment (2003)\*: \*(Source, website airport, 2004)  
 -Employed direct: - -Total on site (est.): 2.266  
 Potential market area 1hr by car 2hrs by car 1hr by train 2hrs by train weighted with distance decay  
 (2004, x 1 million pax): 2,6 21,0 0,2 2,1 7,3

**AIRPORT-INFRASTRUCTURE**

Size - (ha)  
 Runways: 1 -Longest length: 3.040m  
 -Runway 1 Heading 03/21, 3.040m, Aircraft size max: AN-124, B747, AN225  
 Apron (aircraft stands) 19  
 Cargo terminal: 4 -Capacity cargo (tons): 45.000  
 Passenger terminal: 2 -Capacity passengers (annual): 5.000.000

**ACCESSIBILITY**

-Train link: No -Bus link: region bus -Nearest city: Mainz (60km)  
 Modal split: Rail Bus Taxi Private Car Others  
 - - - - -

Parking area (spaces): 9.219  
 -Parking fees (euros, 2004): 2 hrs 1 day 7 days  
 --short term € 1,50 €15,00 €105,00  
 --long term € 1,50 € 5,00 € 25,00

**PLANNED AIRPORT DEVELOPMENT**

-Projects: -Additional capacity: -Year operation: -Status:  
 Extension runway to 3800m + Apron Runway, APRON ? Planned  
 Additional terminal facilities (shops, restaurants and post office) Terminal 2004 Planned  
 Hotel building next to terminal Terminal 2005 Planned  
 Comments: Masterplan for development airport for the future.

-  Airport
-  Motorway
-  Railway
-  National border
-  Built area
-  Water

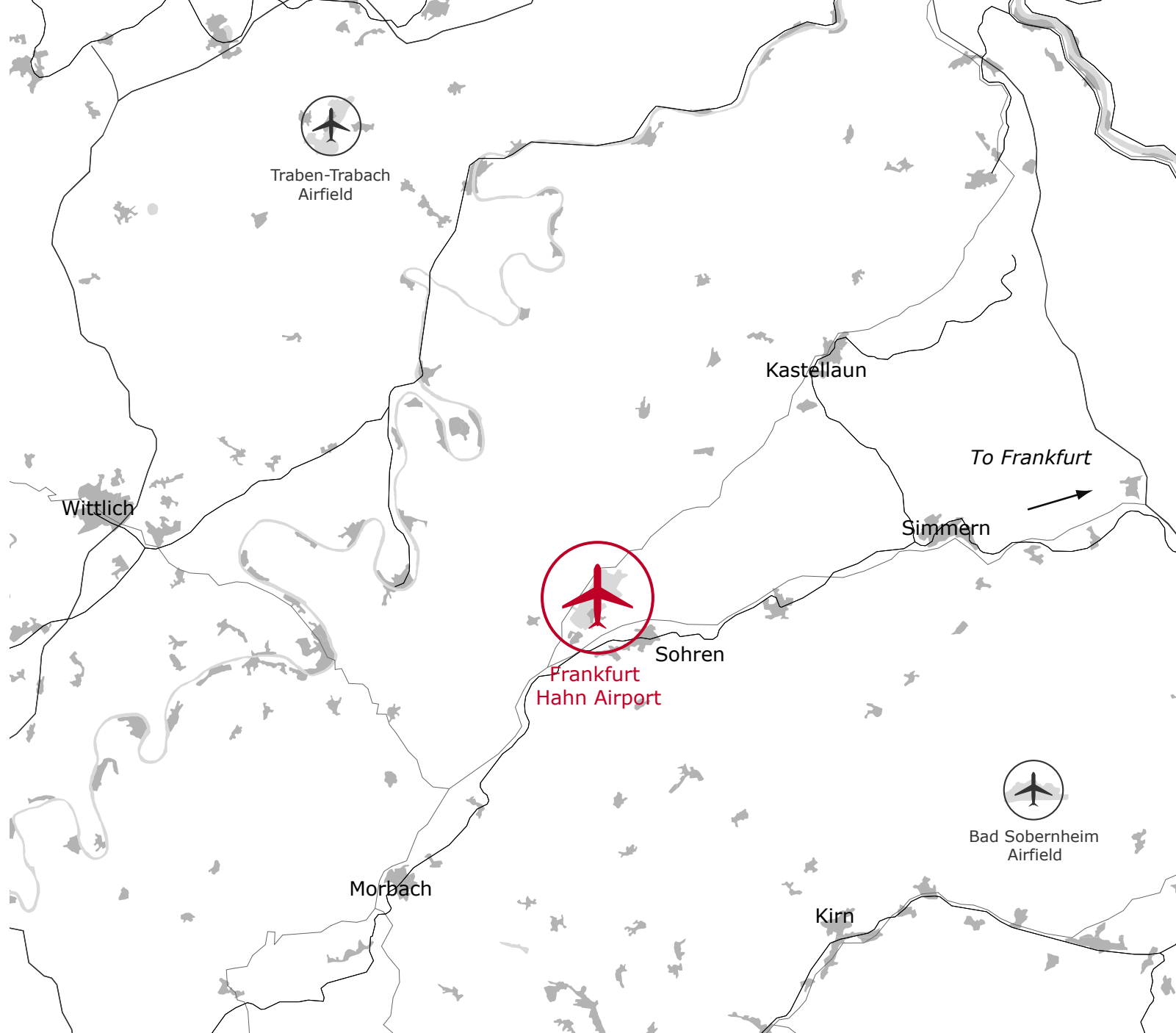

Hahn region

1:300.000



# BRE-BREMEN AIRPORT (D)

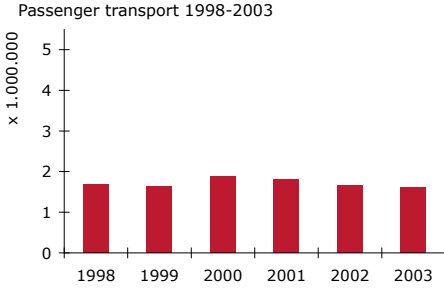

**CONNECTIVITY** (summer 2004)

Destinations:	60
-Scheduled flights	35
-Holiday flights	25
Airlines	15

**AIR TRAFFIC**  
(statistics 2003, x 1.000)\*

Air transport movements	Passenger transport (terminal)	Freight transport (metric tons)	Mail transport (metric tons)
42,8	1.612,9	1,2	1,1

\*(Source: IATA, 2004)

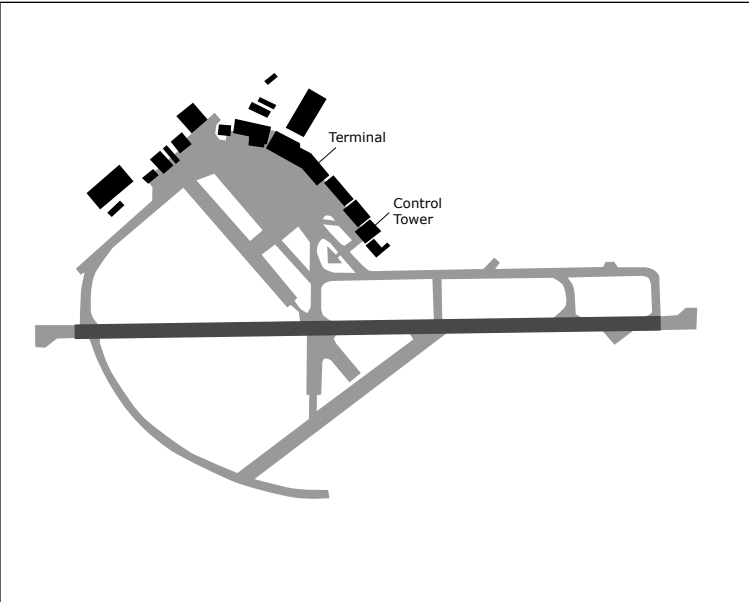

**AIRPORT-ORGANIZATION**

Name / Address	Bremen Airport, Flughafenallee 20, Bremen, D-28199, Germany				
Website	www.airport-bremen.de				
IATA / ICAO code	BRE / EDDW				
Position (LAT/LONG)	53°02' 48"N / 008°47' 12"E				
Opening hours	06:00-22:30 hrs; Chapter 2 of 07:00-22:00 hrs				
(Noise) restrictions	-				
Operator	Flughafen Bremen GmbH				
Employment (2002)*:	*(Source: ATAG, 2003)				
-Employed direct:	254		-Total on site (est.):	2.000	
Potential market area	1hr by car	2hrs by car	1hr by train	2hrs by train	weighted with distance decay
(2004, x 1 million pax):	3,0	16,7	1,9	11,2	5,6

**AIRPORT-INFRASTRUCTURE**

Size	316 ha		
Runways:	1	-Longest length:3.000m	
-Runway 1	Heading 09/27, 3.000m, Aircraft size max: No limit		
Apron (aircraft stands)	29		
Cargo terminal:	1	-Capacity cargo (tons):	-
Passenger terminal:	3	-Capacity passengers (annual):	-

**ACCESSIBILITY**

-Train link:	No	-Bus Link:	-	-Nearest city:	Bremen (4km)
Modal split:	Rail	Bus	Taxi	Private car	Others
	-	-	-	-	-

Parking area (spaces):	4.450		
-Parking fees (euros, 2004):	1 hr	1 day	14 days
--short/long term	-	-	-
--holiday parking	€35,00		

**PLANNED AIRPORT DEVELOPMENT**

-Projects:	-Additional capacity:	-Year operation:	-Status:
Fuel station	Others	?	Planned
Parking garage	Terminal	?	Planned
Fire Brigade Building	Others	?	Planned

-  Airport
-  Motorway
-  Railway
-  National border
-  Built area
-  Water

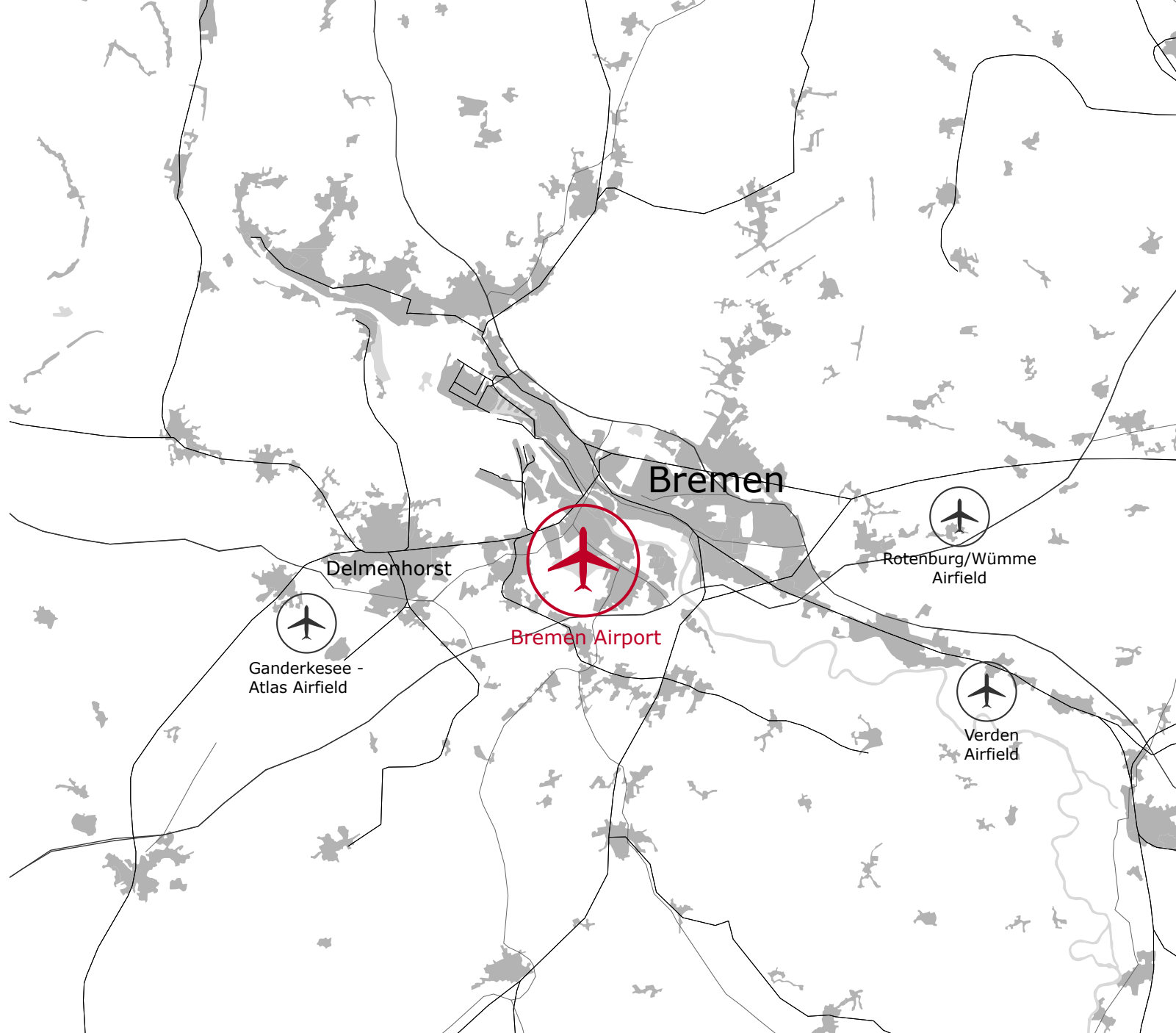

Bremen region

1:300.000

# 112 FMO - MÜNSTER-OSNABRÜCK AIRPORT (D)

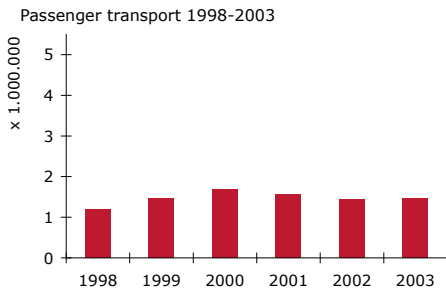

## CONNECTIVITY (summer 2004)

Destinations:	43
-Scheduled flights	7
-Holiday flights	36
Airlines (charters)	4 (8)

## AIR TRAFFIC (statistics 2003, x 1.000)\*

Air transport movements	Passenger transport (terminal)	Freight transport (metric tons)	Mail transport (metric tons)
45,9	1.465,9	0,1	0,7

\*(Source: IATA, 2004)

## AIRPORT-ORGANIZATION

Name / Address	Münster-Osnabrück Airport, Hüttruper Heide 71-81, D-48268 Greven, Germany				
Website	www.fmo.de				
IATA / ICAO code	FMO / EDDG				
Position (LAT/LONG)	52°08' 10"N / 007°41' 09"E				
Opening hours	24 hours				
(Noise) restrictions	only chapter 3 are allowed from 22:00-06:00 hrs				
Operator	FMO Airport Services GmbH				
Employment (2002)*:	*(Source: ATAG, 2003)				
-Employed direct:	336				-Total on site (est.): 2.000
Potential market area	1hr by car	2hrs by car	1hr by train	2hrs by train	weighted with distance decay
(2004, x 1 million pax):	6,7	29,1	1,3	15,1	10,1

## AIRPORT-INFRASTRUCTURE

Size	- (ha)	
Runways:	1	-Longest length: 2.170m
-Runway 1	Heading 07/25, 2.170m, Aircraft size max: B747	
Apron (aircraft stands)	25	
Cargo terminal:	1	-Capacity cargo (tons): 10.000
Passenger terminal:	1	-Capacity passengers (annual): -

## ACCESSIBILITY

Modal split (2002)*:	Rail	Bus	Taxi	Private car	Others
*(Source: ATAG, 2003)	-	7%	7%	86%	-
Parking area (spaces):	8.000				
-Parking fees(euros, 2004):	2 hr	1 day	7 days		
--short term	€ 1,50	€12,00	€84,00		
--long term	€ 1,50	€ 4,00	€19,00		

## PLANNED AIRPORT DEVELOPMENT

-Projects:	-Additional capacity:	-Year operation:	-Status:
Extension runway to 3.600m*	Runway	?	Planned
New maintenance aircraft hangar	Others	2003	Actual

\*Comments: Extension runway to 3,600m will allow international traffic.

-  Airport
-  Motorway
-  Railway
-  National border
-  Built area
-  Water

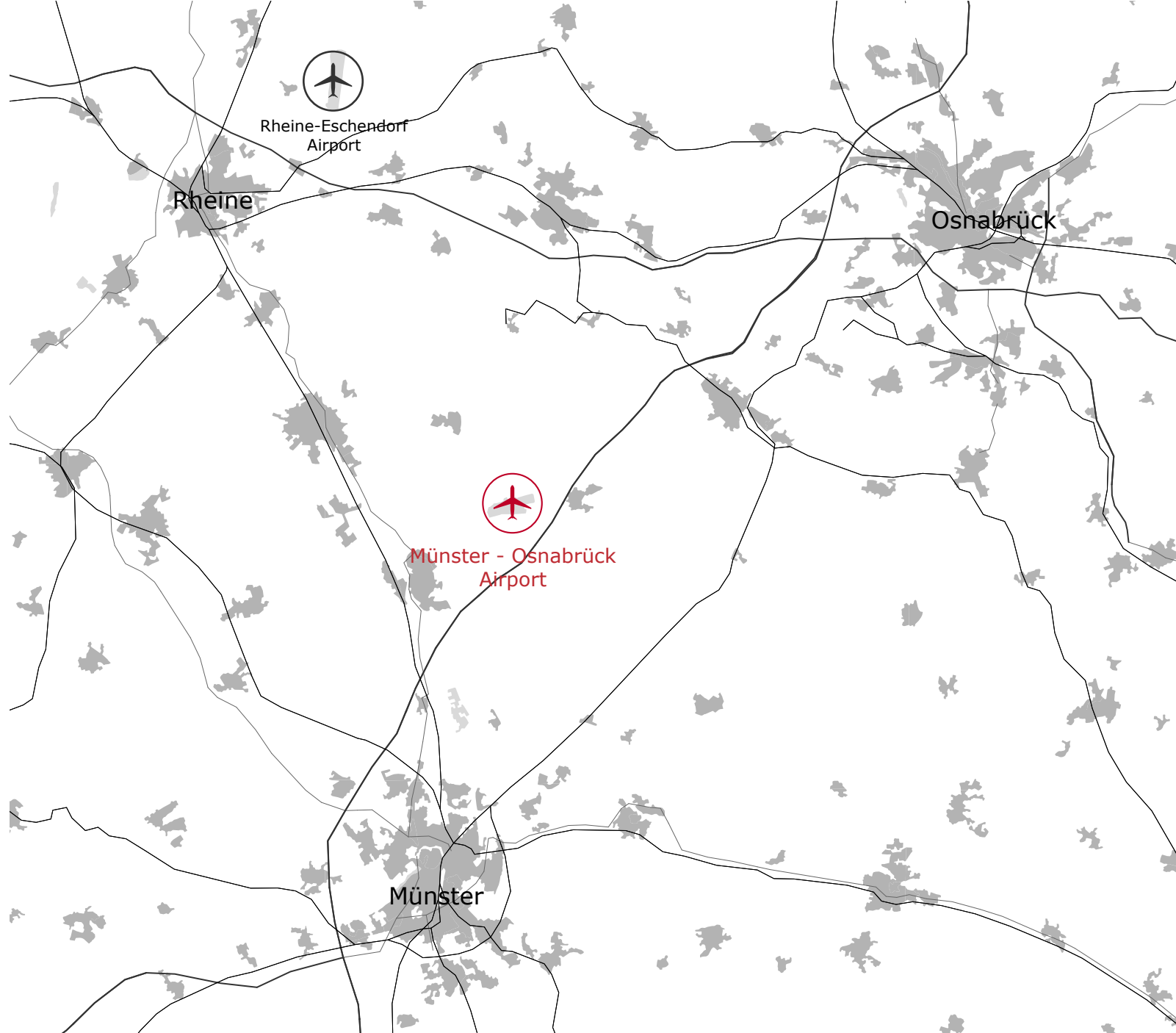

Münster region

1:300.000

# DTM-DORTMUND AIRPORT (D)

Passenger transport 1998-2003

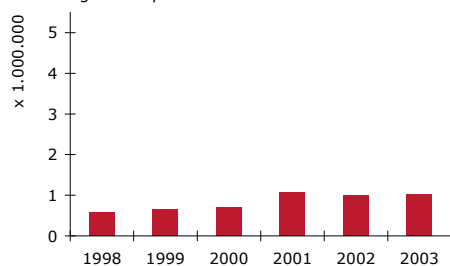

## CONNECTIVITY (summer 2004)

Destinations: 47

-Scheduled flights

-Holiday flights

Airlines 13

## AIR TRAFFIC (statistics 2003, x 1.000)\*

\*(Source: IATA, 2004)

Air transport movements	Passenger transport (terminal)	Freight transport (metric tons)	Mail transport (metric tons)
37,5	1.023,3	5,3	0

## AIRPORT-ORGANIZATION

Name / Address Dortmund Airport, Germany, Flugplatz 7-9, D-44319 Dortmund

Website www.flughafen-dortmund.de

IATA / ICAO code DTM / APXH

Position (LAT/LONG) 51°31'11"N / 007°36'47"E

Opening hours 06:00-22:00

(Noise) restrictions No night flights

Operator Flughafen Dortmund GmbH

Employment (2004): (Source, website airport, 2004)

-Employed direct: -Total on site (est.): 1.338

Potential market area	1hr by car	2hrs by car	1hr by train	2hrs by train	weighted with distance decay
(2004, x 1 million pax):	13,1	33,6	8,5	24,1	13,1

## AIRPORT-INFRASTRUCTURE

Size - (ha)

Runways: 1 -Longest length: 2.000m

-Runway 1 Heading 06/24, 2,000m, Aircraft size max: 75t

Apron (aircraft stands) 6

Cargo terminal: 1 -Capacity cargo (tons): 7.000

Passenger terminal: 1 -Capacity passengers (annual): 2.500.000

## ACCESSIBILITY

-Train link: No -Bus link: Shuttlebus -Nearest city: Dortmund(10km)

Modal split: Rail Bus Taxi Private car Others

-

Parking area (spaces): 3.100

-Parking fees(euros, 2004): 1 hr 1 day 7 days

--short term €2,00 €24,00

--long term €1,00 € 4,00 € 20,00

## PLANNED AIRPORT DEVELOPMENT

-Projects:	-Additional capacity:	-Year operation:	-Status:
new cargo centre	Cargo	2004	Completed

Comments: 2000: completion of and commencement of operations in new terminal and extension of runway to 2,000 metres.

-  Airport
-  Motorway
-  Railway
-  National border
-  Built area
-  Water

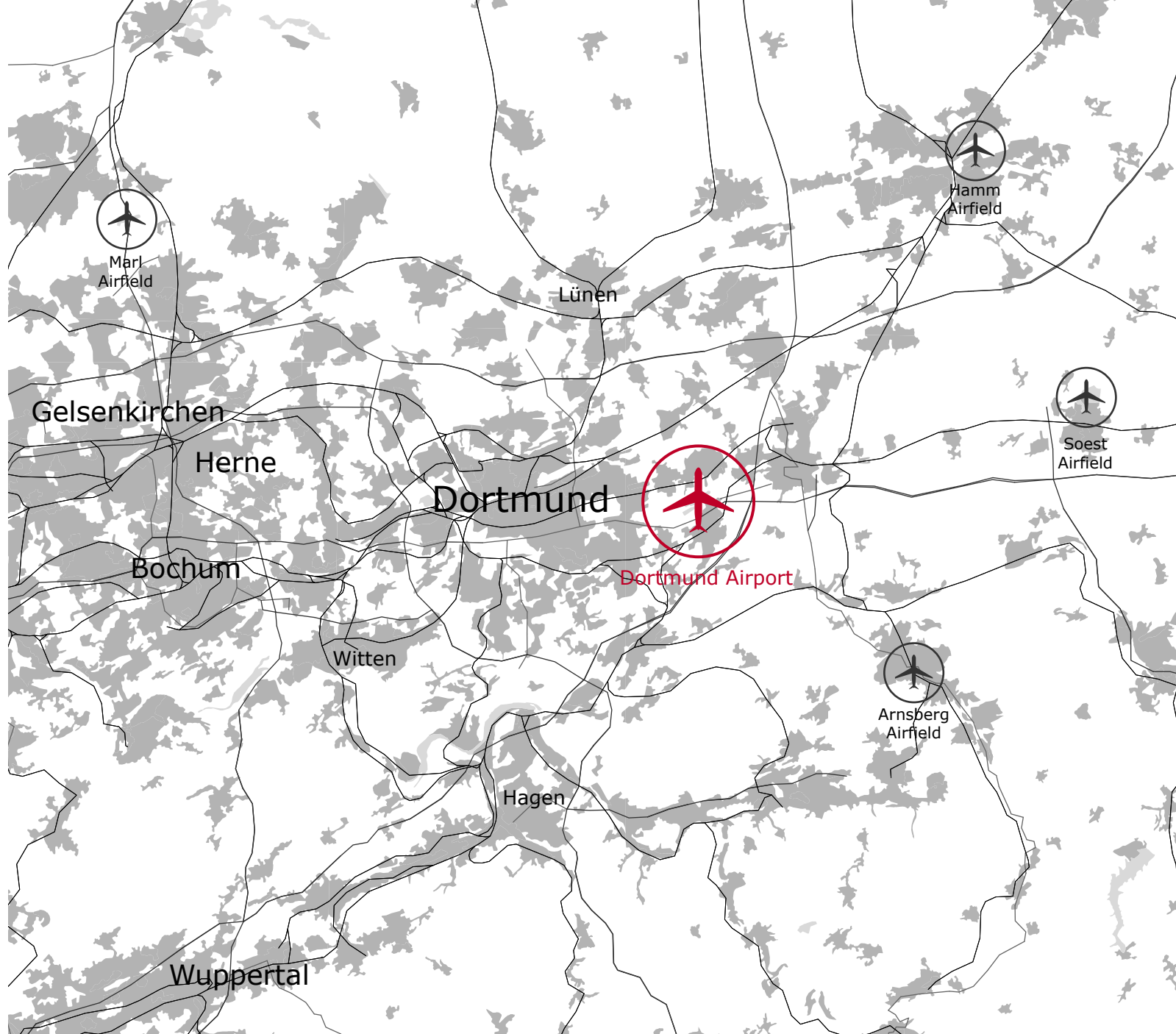

Dortmund region

1:300.000

# 116 NRN-AIRPORT DÜSSELDORF REGIONAL (WEEZE) (D)

## AIRPORT-ORGANIZATION

\*new name as of 11-2004, formerly 'Airport Niederrhein'

Name / Address	Airport Düsseldorf Regional (Weeze)*, Flughafen-Ring 60, D-47652 Weeze, Germany				
Website	www.duesseldorf-regional-weeze.de				
IATA / ICAO code	NRN / EDLV				
Position (LAT/LONG)	51°36' 14"N / 006°08' 53"E				
Opening hours	Summer 04:00-20:00 hrs, weekend/holyday 11:00-13:00 hrs; Winter 05:00-21:00 hrs, weekend/holyday 12:00-14:00 hrs				
(Noise) restrictions	-				
Operator	Airport Düsseldorf -Prefecture Weeze GmbH				
Employment (2004)*:	*(Source: website airport, 2004)				
-Employed direct:	-	-Total on site (est.):	300		
Potential market area	1hr by car	2hrs by car	1hr by train	2hrs by train	weighted with distance decay
(2004, x 1 million pax):	9,4	38,1	0,8	15,4	12,2
Comments:	Former military base; from May 2003 operate as new commercial civil airport for flights of low-cost airlines.				

## AIRPORT-INFRASTRUCTURE

\*(Source: website airport, 2004)

Size	- (ha)				
Runways:	1	-Longest length:	2.440 m		
-Runway 1	Heading 09/27, 2.440m				
Apron (aircraft stands)	-				
Cargo terminal:	-	-Capacity cargo (tons):	-		
Passenger terminal:	1	-Capacity passengers (annual):	2.500.000		
ACCESSIBILITY	-Train link: No -Bus link: Shuttlebus -Nearest city: Weeze (7km)				
Modal split (2002)*:	Rail	Bus	Taxi	Private car	Others
*(Source: ATAG, 2003)	-	-	-	-	-
Parking area (spaces):	1.000				
-Parking fees (euros, 2004):	1 hr	1 day	7 day		
--short term	€ 1,50	€10,00	€70,00		
--long term	€ 1,00	€ 6,00	€30,00		

## PLANNED AIRPORT DEVELOPMENT

-Projects:	-Additional capacity:	-Year operation:	-Status:
-	-	-	-

Comments: Airport has been renovated in 2003 to become a commercial civil airport.

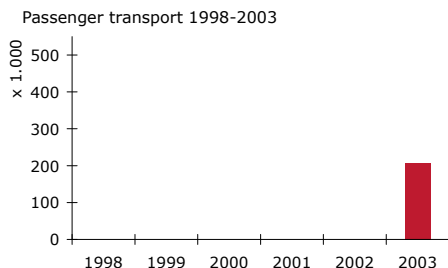

## CONNECTIVITY (summer 2004)

Destinations:	14
-Scheduled flights	5
-Holiday flights	9
Airlines	5

<b>AIR TRAFFIC</b> (statistics 2003, x 1.000)*	Air transport movements	Passenger transport (terminal)	Freight transport (metric tons)	Mail transport (metric tons)
*(Source: ADV-net, 2004)	3,5	208,1	-	0

-  Airport
-  Motorway
-  Railway
-  National border
-  Built area
-  Water

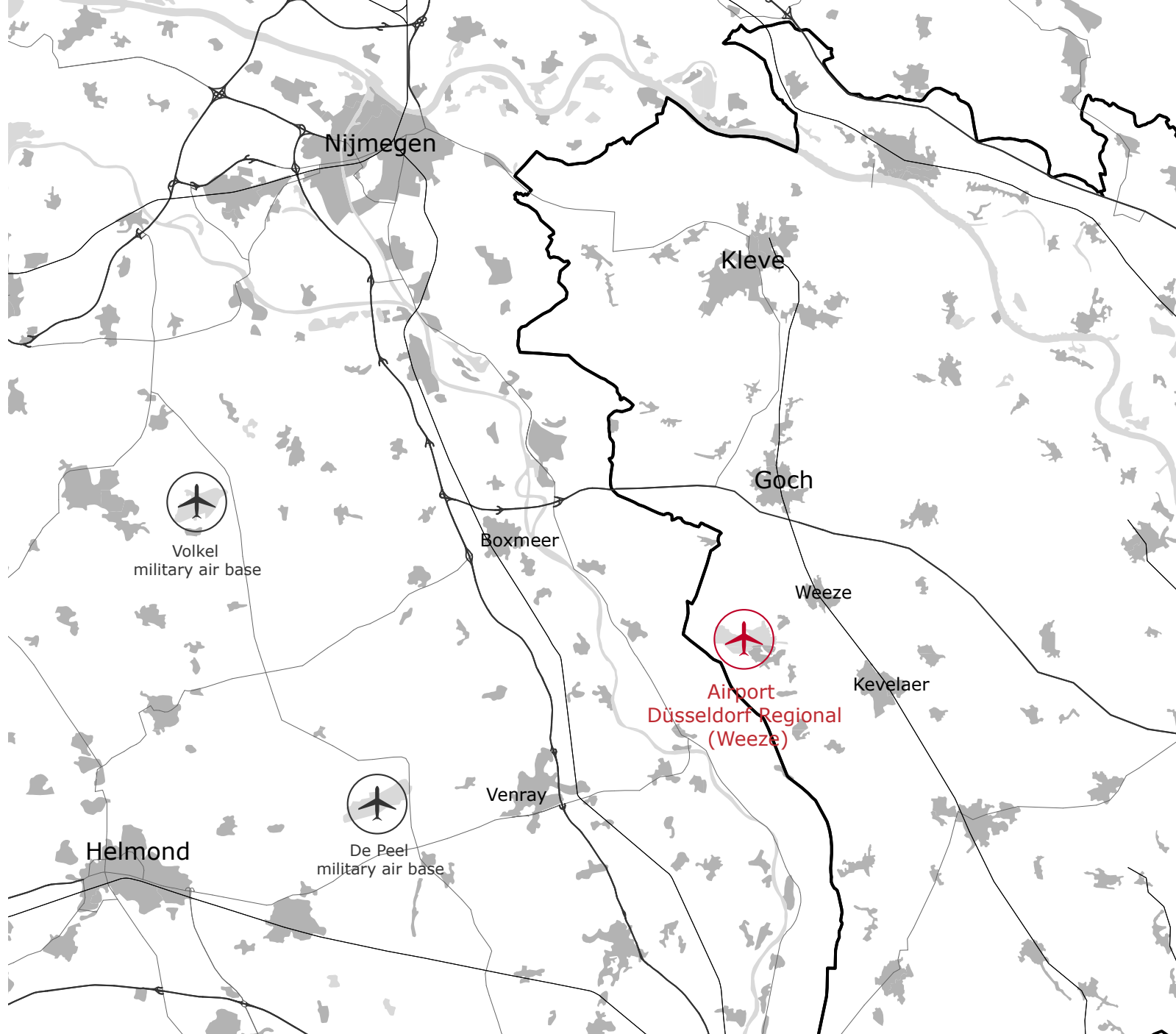

Weeze region

1:300.000



# 118 MGL-DÜSSELDORF AIRPORT -MÖNCHENGLADBACH (D)

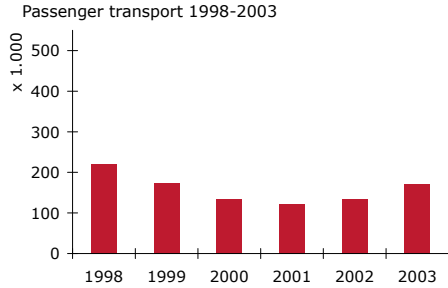

## CONNECTIVITY (summer 2004)

Destinations:	2
-Scheduled flights	2
-Holiday flights	
Airlines	-

AIR TRAFFIC (statistics 2003, x 1.000)*	Air transport movements	Passenger transport (terminal)	Freight transport (metric tons)	Mail transport (metric tons)
*(Source: ITA, 2004)	59,8	169,8	0,3	0

## AIRPORT-ORGANIZATION

Name / Address	Düsseldorf Airport-Mönchengladbach, Flughafenstraße 95, D-41066 Mönchengladbach, Germany				
Website	www.mgl.de				
IATA / ICAO code	MGL / EDLN				
Position (LAT/LONG)	51°13'54"N / 006°30'19"E				
Opening hours	06:00-22:00 hrs				
(Noise) restrictions	-				
Operator	Flughafen Mönchengladbach GmbH				
Employment:					
-Employed direct:	-		-Total on site (est.):	-	
Potential market area	1hr by car	2hrs by car	1hr by train	2hrs by train	weighted with distance decay
(2004, x 1 million pax):	12,6	27,3	8,3	22,0	13,8

## AIRPORT-INFRASTRUCTURE

Size	116 (ha)			
Runway:	1	-Longest length:	1.200 m	
-Runway 1	Heading, 1.200m			
Apron (aircraft stands)	6			
Cargo terminal:	1	-Capacity cargo (tons):	-	
Passenger terminal:	2	-Capacity passengers (annual):	600.000	

## ACCESSIBILITY

	-Train link:No -Bus link:Bus 010 -Nearest city:Düsseldorf (20km)				
Modal split (2002)*:	Rail	Bus	Taxi	Private car	Others
*(Source: ATAG, 2003)	-	-	-	-	-
Parking area (spaces):	900				
-Parking tariffs(euros, 2004)	1 hr	1 day	7 days		
--short/long term	free	€4,00	€27,00		

## PLANNED AIRPORT DEVELOPMENT

-Projects:	-Additional capacity:	-Year operation:	-Status:
Extension runway to 2.340 m	Runway	2006	Planned
new passenger terminal (3 million pax)	Terminal	2006	Planned

-  Airport
-  Motorway
-  Railway
-  National border
-  Built area
-  Water

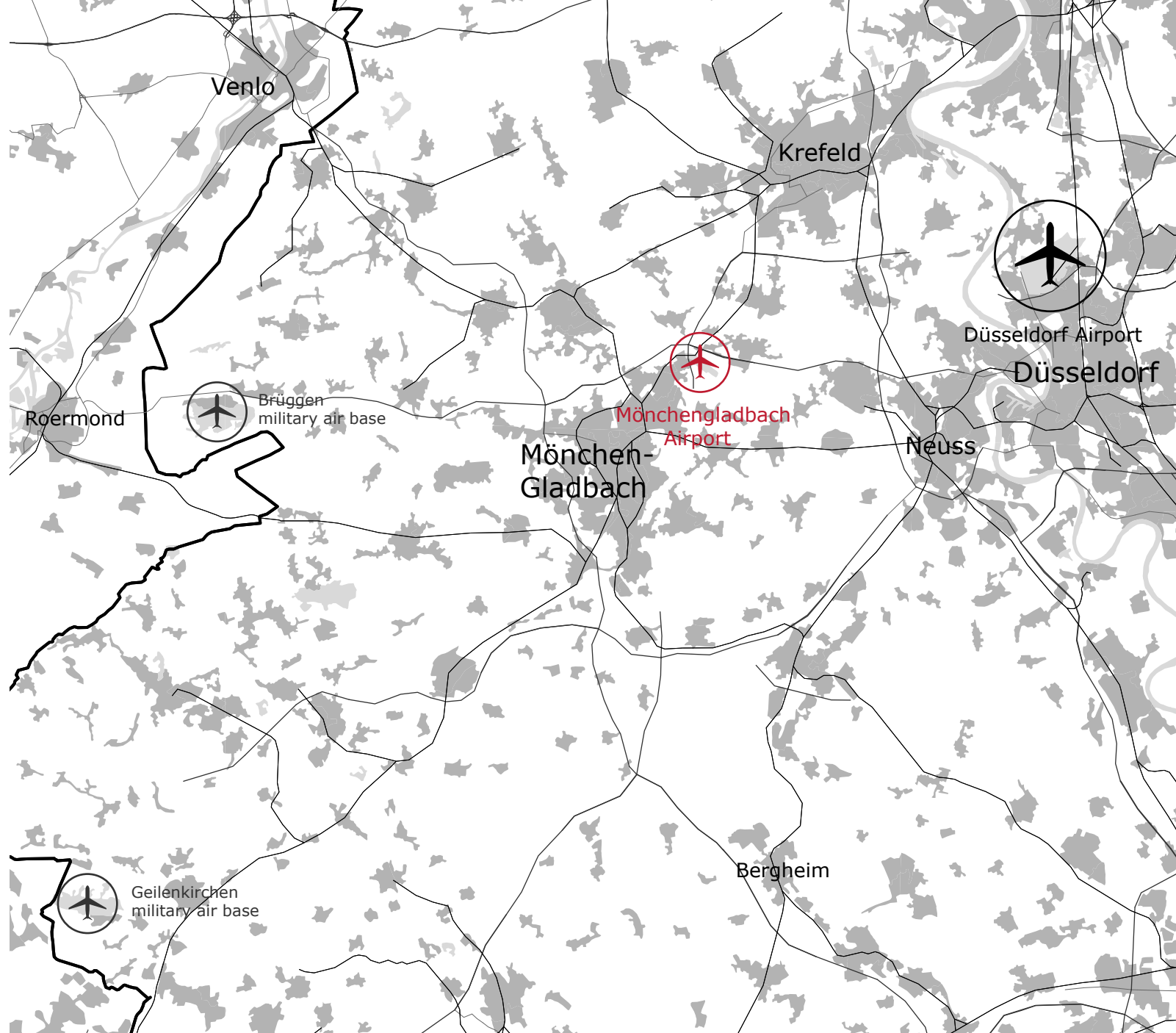

Mönchengladbach  
region

1:300.000